



Taylor Valve
Technology

MCX SERIES Choke Valves



Precise.

Quality.

Reliable.



SINCE 1958



Taylor Valve Technology Multi-Orifice Valve Design Principle Provides Precision Control. The two adjacent internal discs each contain two precision orifices.

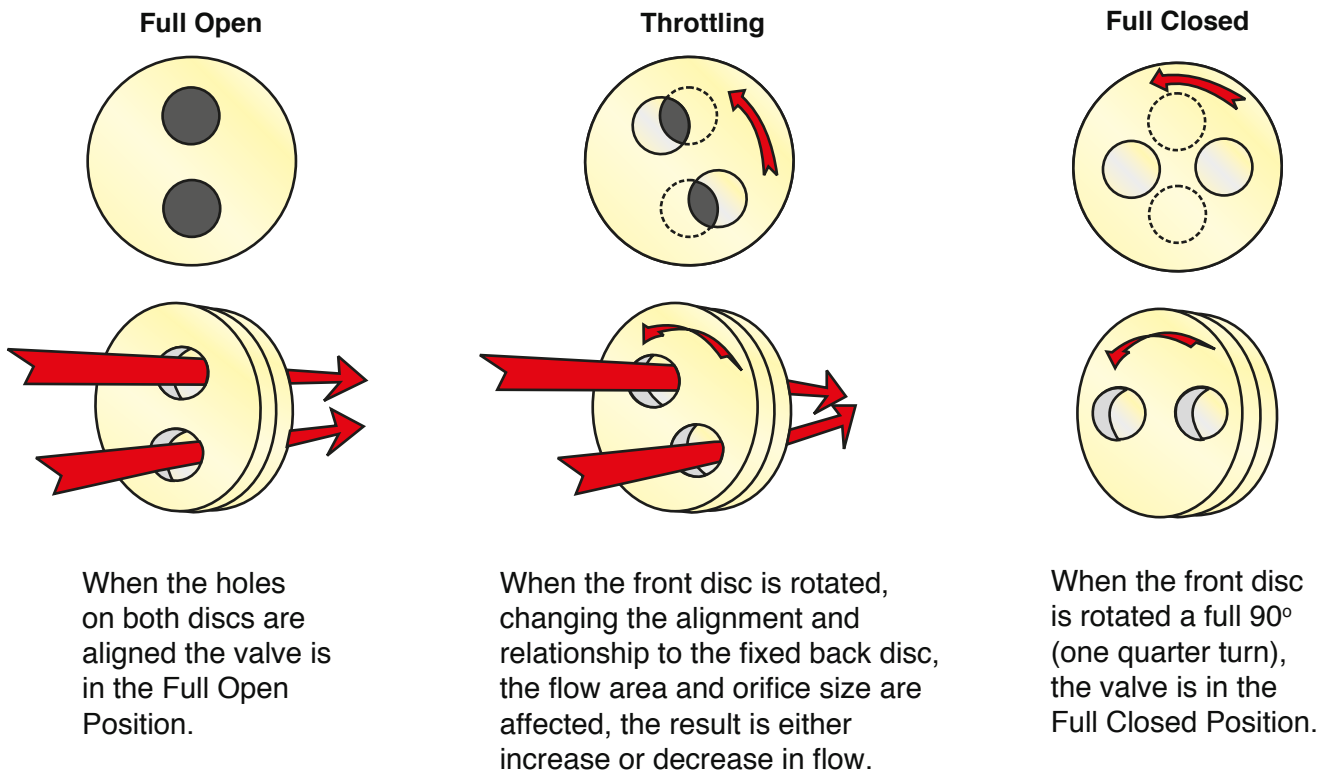

The discs are lapped to within two light bands of flatness (+/- .00002") to achieve positive shut off and maintain precise control. The fixed back disc is held perpendicular to the flow. The front disc floats against the back disc and seeks a mating surface promoting a positive seal. The differential pressure across the upstream disc and the downstream disc stabilizes the control surfaces. Vibration, noise or fatigues normally associated with loose or unsupported parts are eliminated. No control surfaces are introduced into the orifice, providing a clear center line for the flow. The valves are rated for shut-off at ANSI Class III or IV depending on the style of valve and trim used. The orifices of the standard disc expose a small control surface profile to the fluid steam reducing wear. The multi-orifice design produces near linear flow characteristics. The low torque and quarter-turn design of Taylor Valve Technology's Multi-orifice valves allows for a variety of actuation options: manual, pneumatic, hydraulic, or electric.

MCX CHOKE STANDARD DIMENSIONS (IN. +/- .10)

CONNECTION	SIZE		
	3"	4"	6"
FNPT	9.00	12.50	-
BUTT-WELD	-	-	-
150 # RFF	9.00	13.25	15.07
150 # RTJ	9.00	13.25	15.07
300 # RFF	9.50	13.25	15.07
300 # RTJ	9.50	13.25	15.07
600 # RFF	9.50	13.25	15.07
600 # RTJ	9.50	13.25	15.07
900 # RFF	9.50	13.25	-
900 # RTJ	9.50	13.25	-
1500 # RFF	9.50	13.25	-
1500 # RTJ	9.50	13.25	-
2500 # RFF	-	-	-
2500 # RTJ	-	-	-

MCX Inline Choke

3" & 4" Configurations
 1018/1020 CS, 316 SS)
 ¼ Turn Actuated
 Body Rating = 3,000 PSI
 CV Range = 11.2 – 279.83

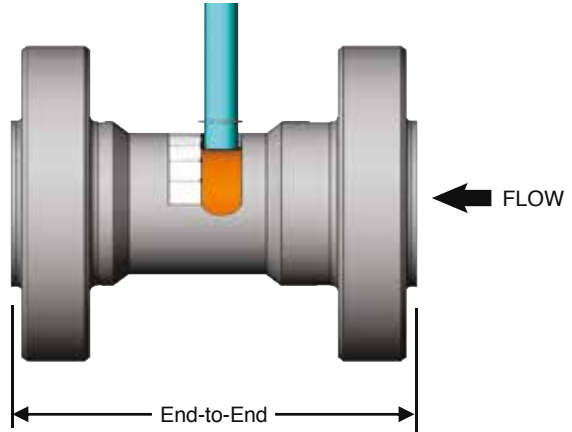

No.	Description	Qty
1	Body	1
2	Rotator	1
3	Disc	2
4	O-Ring	4
5	O Ring	1
6	Dowel Pin	4
7	Handle	1
8	Spiral Retaining Ring	1
9	Retaining Ring	4
**10*	Wear Sleeve	1

*Not available in threaded configuration
 ** Not shown in section view

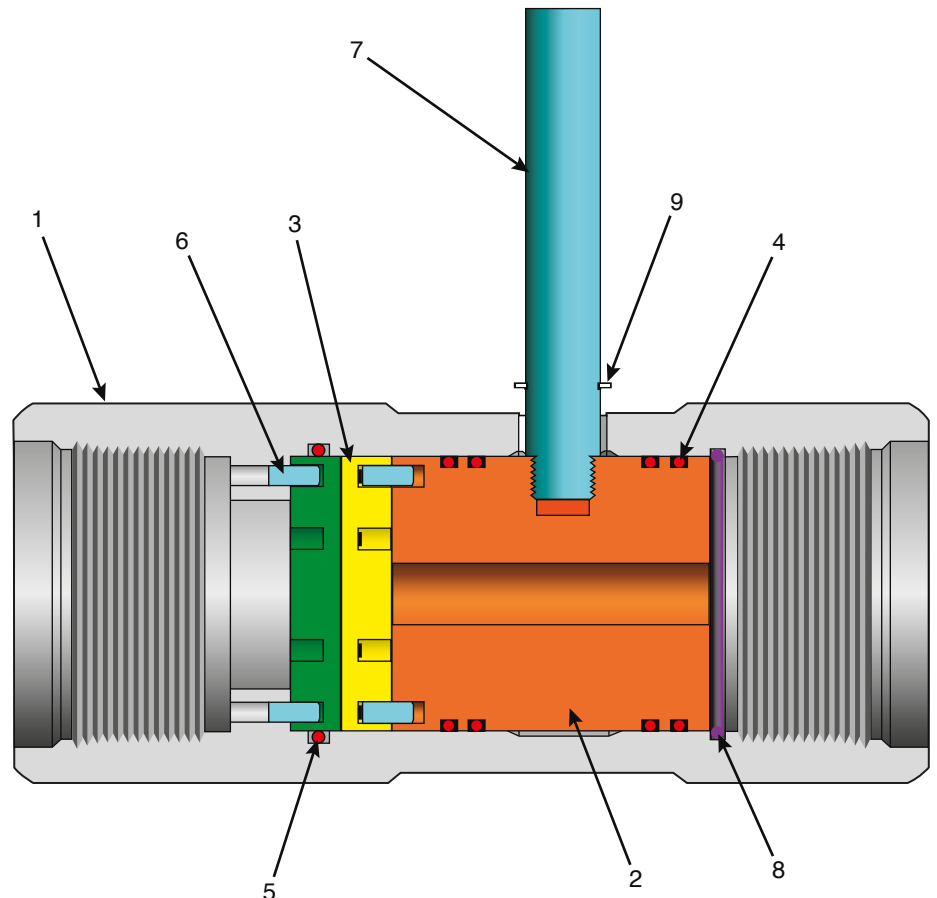

The information contained in these drawings is the sole property of Taylor Valve Technology Inc. and any reproduction in part or whole without the written permission of Taylor Valve Technology Inc. is prohibited.

NOTE: Taylor Valve reserves the right to change product designs and specifications without notice.

MCX SERIES CHOKE VALVES

FEATURES & *Benefits*

- **Accurate Control** - Superior design is unequalled for throttling control and accuracy. Unique sealing and fluid flow dynamics permit compliance with current environmental requirements.
- **Extended Mean Time Between Service** - Robust design and liberal application of hardened materials, efficient flow-geometry means the valves offer maximum production potential and minimum service requirements.
- **Easy Maintenance** - Choke valves are designed to provide simple straightforward disassembly with no special tooling or fixtures.
- **Optional Features** - Choke valves can have trims and actuators custom designed for specific requirements, such as, special trims for noise reduction and sand control, several trims are available to accommodate high pressure flows or minimum pressure loss applications.

Applications:

- Water Injection Control Valve
- Gas Lift Injection Control
- Throttling Valve
- High DP Valve
- Motor Operated Valve
- Enhanced Oil Recovery



The MCX Series of Inline MOV Chokes Offer:

- ~ ANSI Class III Shut Off
- ~ Linear flow characteristics
- ~ Downstream Wear Resistant Flow Tube
- ~ Simple Design for easy field maintenance
- ~ Choice of materials for body standard is 316 SS
- ~ Threaded, Flanged
- ~ Sizes from 3" to 4" Flanged

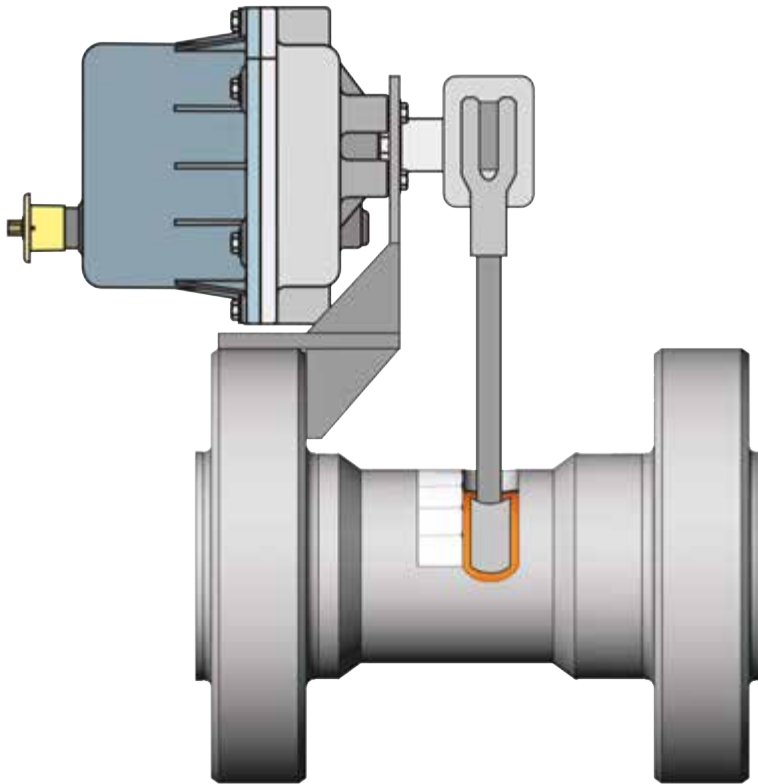

Control Element Disc

Tungsten Carbide above 500 psi up to maximum operating pressure of valve.

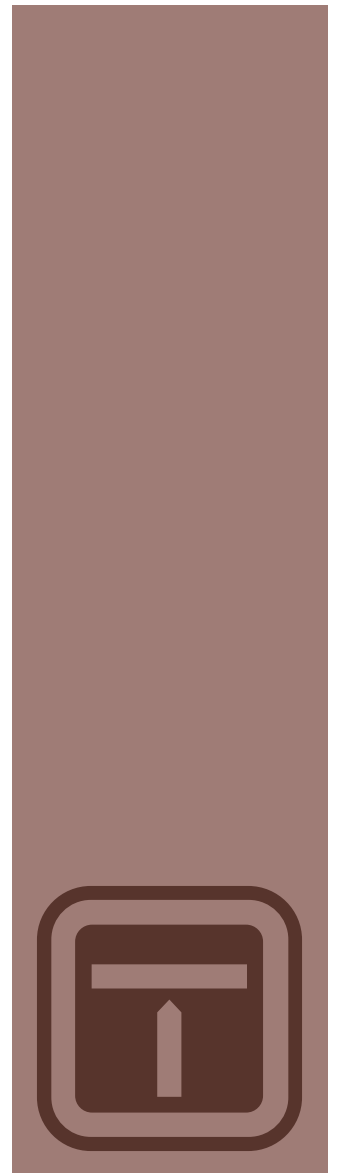
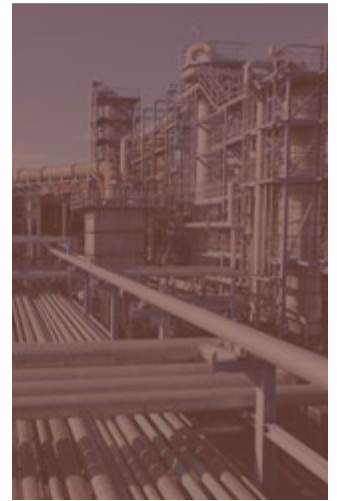
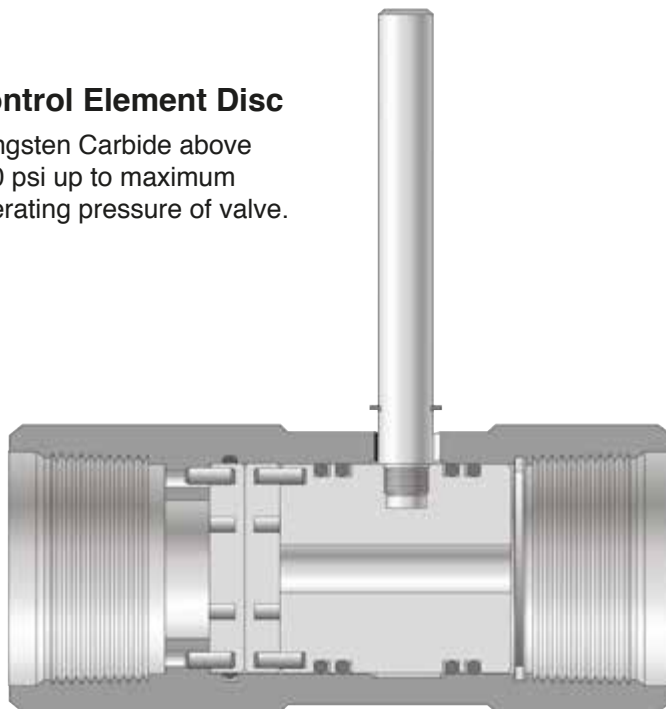

MCX Actuation Packages

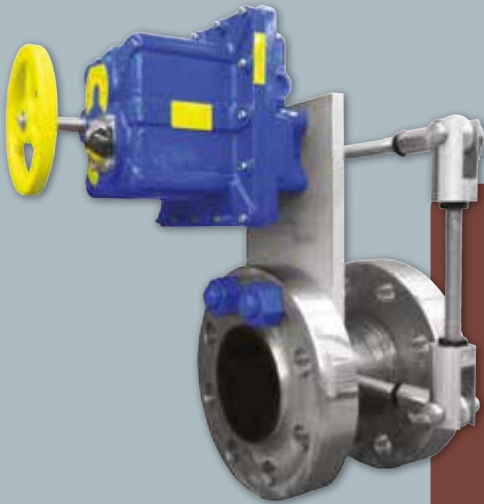

MCX 3" with 4" 900# RFF

MCX with Electric Actuator

Actuator Shown - Indelac Male LX-14

- 24 Volt DC Supply
- Max Torque 3840 in. lbs.
- NEMA 4 Enclosure
- Side Mounted Hand wheel (optional)
- Used on MCX 3" & 4"

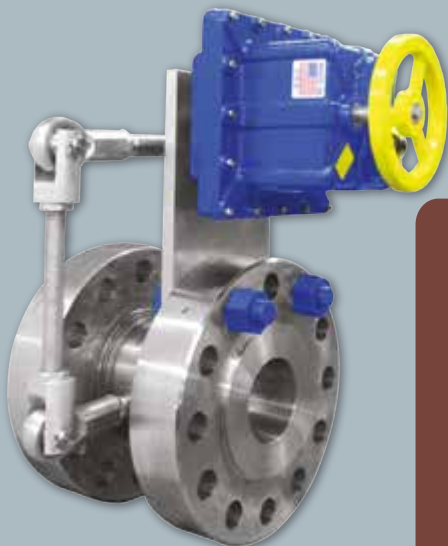

MCX 4" with 6" 900# RFF

MCX with Electric Actuator

Actuator Shown - Indelac Female LX-14

- 24 Volt DC Supply
- Max Torque 3840 in. lbs.
- NEMA 4 Enclosure
- Side Mounted Hand wheel (optional)
- Used on MCX 3" & 4"

MCX Actuation Packages

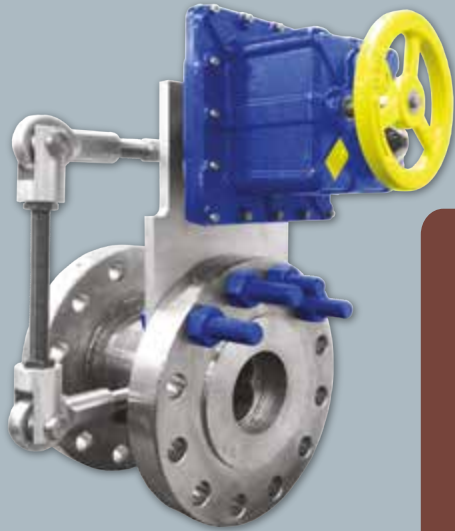

MCX 4" with 6" 1500# RFF

MCX with Electric Actuator

Actuator Shown - Indelac LX-5

- 24 Volt DC Supply
- Max Torque 1500 in. lbs.
- NEMA 4 Enclosure
- Side Mounted Hand wheel (optional)
- Used on MCX 3" & 4"



MCX 4" with 4" 1500# RFF

MCX with Electric Actuator

Actuator Shown - Rotork IQTM 500

- Single Phase 120 Volts supply
- Max 500Nm torque actuator
- NEMA 4 Enclosure
- Side Mounted Hand wheel
- Used on MCX 3" & 4"

Taylor Valve MCX Series

Choke Nomenclature

Choke Series
CA
CI
MC
MCX
MDA
MDAS
MDI
MDIS
RB
R

Size
1 1"
2 2"
3 3"
4 4"
6 6"

Service Type
0 Standard
1 NACE
2 Steam/High Temp.

Actuation Type
0 Manual Handle
1 Manual Gear
2 Electric
3 Pneumatic
4 Hydraulic
7 Positive Bean

Style
0 Non-flanged
1 RFF
2 RTJ
3 RFF X RTJ
4 RTJ X RFF

Schedule
0 Non-flanged
1 40
2 80
3 160
4 XS
5 XXS
6 SLIP-ON
7 API
8 120

Trim Material
03 CARBIDE DISC - STELLITE WR SLV
04 CERAMIC DISC - STELLITE WR SLV
05 CARBIDE DISC - CARBIDE WR SLV
15 CERAMIC DISC - NO WR SLV
16 CARBIDE DISC - NO WR SLV
32 CERAMIC DISC/CARBIDE FLOW TUBE
44 R/RB-SERIES
47 BEAN 17-4 SS

Body Material
00 DUPLEX SS
03 CARBON STEEL
04 LOW ALLOY (4130 LACS)
05 316 SS (CF8M)
06 316 SS "L" (CF3M)
07 ALUMINUM BRONZE
08 A350 LF2
09 LCC
11 SUPER DUPLEX SS

EXAMPLE ONLY* MCX - 3 0 0 27 27 1 6 35 16 05 04 = MCX-30027271635160504
Choke part number has to be 17 digits.

Inlet Connection		Outlet Connection	
01	1" FNPT	41	6" 600
02	1" BUTT WELD	42	6" 900
03	1" SOCKET WELD	43	6" 1500
04	1" VICTAULIC	44	6" 2500
05	1" 150	45	8" 150
06	1" 300	46	8" 300
07	1" 600	47	8" 600
08	1" 900/1500	48	8" 900
09	1" 2500	49	8" 1500
10	2" FNPT	50	8" 2500
12	2" BUTT WELD	51	2-1/16" 3000
13	2" SOCKET WELD	52	2-1/16" 5000
14	2" VICTAULIC	53	2-1/16" 10000
15	2" 150	54	2-9/16" 3000
16	2" 300	55	2-9/16" 5000
17	2" 600	56	2-9/16" 10000
18	2" 900/1500	57	3-1/8" 3000
19	2" 2500	58	3-1/8" 5000
20	3" FNPT	59	3-1/8" 10000
21	3" BUTT WELD	60	4-1/16" 3000
22	3" SOCKET WELD	61	4-1/16" 5000
23	3" 150	62	1-13/16" 10000
24	3" 300	63	3-1/16" 5000
25	3" 600	64	3/4" 600#
26	3" 900	65	1.5" 900/1500
27	3" 1500	66	3-1/16" 10000
28	3" 2500	67	7-1/16" 5000
29	4" FNPT	68	1-13/16" 15000
30	4" BUTT WELD	69	2-1/16" 15000
31	4" SOCKET WELD	75	1" UNION
32	4" VICTAULIC	76	3" 602M x 3" 602F Union
33	4" 150	80	10" 600
34	4" 300	81	10" 900
35	4" 600	82	10" 1500
36	4" 900	83	10" 2500
37	4" 1500	84	2-9/16" 15000
38	4" 2500	85	6" Butt Weld
39	6" 150		
40	6" 300		

Orifice Size	
01	(2) 1/8" RND PORTS
02	(2) 3/16" RND PORTS
03	(2) 1/4" RND PORTS
04	(2) 3/8" RND PORTS
05	(2) 1/2" RND PORTS
06	(2) 5/8" PIE PORTS
07	(2) 3/4" RND PORTS
08	(2) 7/8" RND PORTS
10	(2) 1-3/16" RND PORTS
11	(2) 1-1/4" RND PORTS
14	(2) 1-1/2" RND PORTS
30	(2) 3/4" PIE PORTS
35	(2) 1" ROUND PORTS
38	(2) 2" PIE PORTS
40	(2) 1-1/4" PIE PORTS
41	(2) 1-3/8" PIE PORTS
42	(2) 1-1/8" RND PORTS
47	(2) 1-1/2" PIE PORTS
49	(2) 5/8" RND PORTS
54	(2) 2.92 PIE HOLES
55	3 CV
56	12 CV
57	164 CV
58	420 CV
59	64 CV
60	35 CV
22	17/64 BEAN
23	18/64 BEAN
24	8/64 BEAN
25	13/64 BEAN
26	4/64 BEAN
27	38/64 BEAN
28	36/64 BEAN
29	48/64 BEAN
34	32/64 BEAN
43	40/64 BEAN
44	34/64 BEAN
45	28/64 BEAN
46	30/64 BEAN
53	10/64 BEAN
63	11/64 BEAN
64	14/64 BEAN
65	15/64 BEAN
66	16/64 BEAN
67	19/64 BEAN
68	20/64 BEAN
69	24/64 BEAN
70	21/64 BEAN
71	22/64 BEAN
72	23/64 BEAN
73	27/64 BEAN
74	29/64 BEAN
75	25/64 BEAN
76	1/7" RND PORTS
77	7/64 BEAN
78	54/64 BEAN
79	44/64 BEAN
80	45/64 BEAN
81	47/64 BEAN
82	51/64 BEAN
83	35/64 BEAN
84	37/64 BEAN
85	6 CV
87	12/64 BEAN
88	78 CV

Seal Material	
00	HNBR/HSN
01	NBR
03	EPDM
04	FKM (VITON)
05	NEOPRENE
06	NBR (PEROXIDE CURED)
07	STEAM SEALS
09	AFLAS
12	KALREZ

PINS	
1	INCONEL (Optional)

Butt weld connections MUST specify a schedule.
All API connections are "RTJ" style by default.
API flange bore (SCHEDULE) is specified by API.

*For more options, contact Taylor Valve.

REVISED: 10-05-17

Taylor Valve Technology
8300 S.W. 8th Street
Oklahoma City, Oklahoma 73128

TEL 405.787.0145
FAX 800.805.3401

WEB www.taylorvalve.com
EMAIL info@taylorvalve.com